



Features

- Runs on browsers, no extra software tool is required.
- No more programming, Web pages provided for control logic editing.
- IF-THEN-ELSE logic rules execution ability.
- Built-in I/O AI: 10/20 Channels
- Support I/O Monitoring/Control, Counter, Timer, Email sending and CGI Command sending operations.
- Modbus TCP Protocol for SCADA System Integration.
- IEEE 802.3af-compliant Power over Ethernet (PoE).
- 2-port Ethernet Switch for Daisy-Chain Topology.
- Support Schedule operation
- MQTT Protocol for IT & IoT (Internet of Things) System Integration.



Introduction

WISE (Web Inside, Smart Engine) is a product series developed by ICP DAS that functions as control units for use in remote logic control and monitoring in various industrial applications. WISE offers a user-friendly and intuitive web site interface that allows users to implement IF-THEN-ELSE control logic on controller just a few clicks away; no programming is required. With its powerful and easy-to-use features, it will minimize the learning curve, shorten time to market and dramatically reduce the labor and cost spent on system development.

WISE-7517M-10 is a module with 10-channel differential or 20-channel single-ended analog inputs. It provides programmable input range on all analog channels. Each analog channel has 240 Vrms high overvoltage protection. Each analog input can be programmed to accept voltage or current as input depending upon the position of corresponding jumper. It also has qualification for 4 kV ESD protection as well as 3000 VDC intra-module isolation. WISE-7517M-10 follows IEEE 802.3af-compliant Power over Ethernet (PoE) specification. It allows receiving power from PoE enabled network by Ethernet pairs. In addition to this, WISE-7517M-10 also has a built-in two-port Ethernet switch to implement daisy-chain topology. The cabling is much easier and total costs of cable and switch are significantly reduced.

By integrating with IF-THEN-ELSE rule engine, WISE-7517M-10 provides powerful functions such as I/O Monitoring/Control, Counter, Timer, Schedule, E-mail sending & CGI Command sending for use in various industrial applications. WISE-7517M-10 also supports Modbus TCP and MQTT protocols to make seamless integration with SCADA, IT and IoT (Internet of Things) system.

I/O Specifications

Analog Input		
Channels	10 differential or 20 single-ended (Note1), software selectable	
Type	+/-150 mV, +/-500 mV, +/-1 V, +/-5 V, +/-10 V +/-20 mA, 0 ~ 20 mA, 4 ~ 20 mA (Jumper Selectable)	
Resolution	16-bit	
Sampling Rate	10 Samples/Second (Total)	
Accuracy	+/-0.1%	
Zero Drift	+/-20 μ V/°C	
Span Drift	+/-25 ppm/°C	
Overvoltage Protection	Differential	240 Vrms
	Single-ended	150 Vrms
Common Voltage Protection	\pm 200 Vdc	
Overcurrent Protection	Yes, 50 mA at 110 Vdc	
Virtual Channel to Channel Isolation	Yes, 400 Vdc	
Open Wire Detection for 4 ~ 20 mA	Yes	
Input Impedance	Voltage	2 M Ω (Differential), 1 M Ω (Single-ended)
	Current	125 Ω
Common Mode Rejection	86 dB Min.	
Normal Mode Rejection	100 dB	
Note1: Differential mode can be used for voltage input and current input. Single-Ended mode can be used for voltage input only.		

System Specifications

Communication	
Ethernet Port	2 x RJ-45, 10/100 Base-TX, Switch Ports
PoE	Yes
Protocol	Modbus TCP, MQTT
LED Indicators	
for System Running	Yes
for Ethernet Link/Act	Yes
for I/O Channel Status	Yes
for PoE Power	Yes
2-Way Isolation	
I/O	2500 Vdc
EMS Protection	
ESD (IEC 61000-4-2)	\pm 4 kV Contact for Each Terminal and \pm 8 kV Air for Random Point
EFT (IEC 61000-4-4)	\pm 2 kV for Power Line
Surge (IEC 61000-4-5)	\pm 2 kV for Power Line
Power	
Reverse Polarity Protection	Yes
Powered from Terminal Block	12 to 48 Vdc
Powered from PoE	Yes, IEEE 802.3af, Class1
Consumption	3.7 W (Max.)
Mechanical	
Dimensions (L x W x H)	120mm x 97mm x 42mm
Installation	Wall mounting
Environment	
Operating Temperature	-25 °C to +75 °C
Storage Temperature	-30 °C to +80 °C
Humidity	10 to 90% RH, non-condensing

Software Specifications

Functions	
Rule Configuration Website	Access Web server on WISE controllers to edit and upload logic rules through web browser.
72 IF-THEN-ELSE Logic Rules	3 IF conditions with AND or OR operators 3 THEN actions and 3 ELSE actions
48 Internal Registers	Hold temporary variables and read/written via Modbus command.
24 Timers	Delay / Timing functions.
24 Schedules	Setup prescheduled routine tasks.
24 Emails	Send Email messages to pre-set Email receivers.
24 CGI Commands	Send pre-set CGI commands.
24 Recipes	Set up THEN/ELSE action groups.
8 P2P remote modules	Set up the connection information for the remote WISE modules.
Modbus TCP Protocol	Real time control and monitoring I/O channels and system status of controllers via SCADA software.
MQTT Protocol	Real time message publish/subscribe mechanism for I/O channels and system status via IT/IoT software.

IF Conditions	
AI Channel	=, >, <, >=, <= (value)
Internal Register	
Timer	Timeout, Not Timeout
Schedule	In Range, Out of Range
P2P	DI, AI, DI counter, DO counter, IR
Rule Status	Enable, Disable

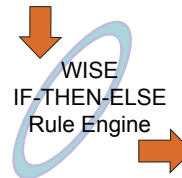

THEN / ELSE Actions	
Internal Register	Change the value
Timer	Start, Reset
Schedule	Enable, Disable
Email	
MQTT message	Send
CGI Command	
Recipe	Execute
P2P	DO(On/Off), AO, IR
Rule Status	Enable, Disable

Wire Connections

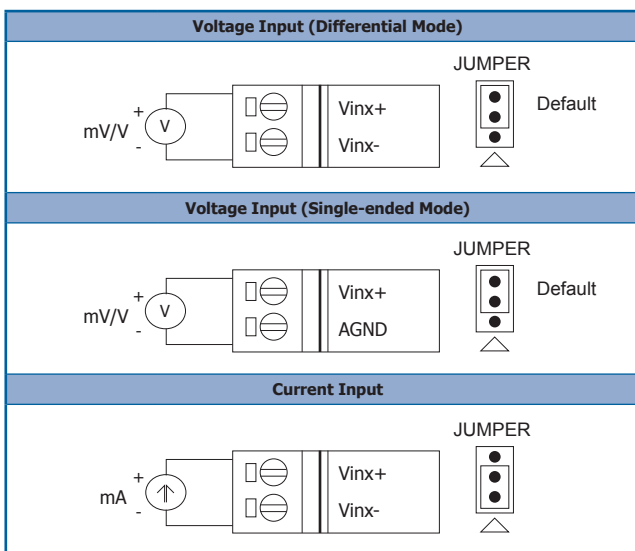

Pin Assignments

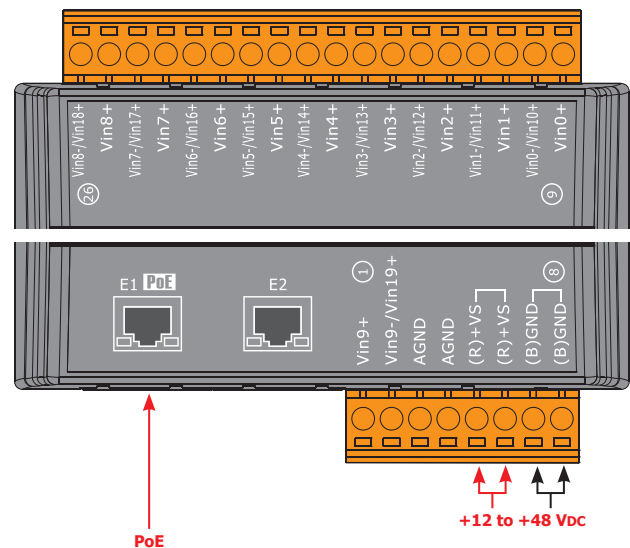

Ordering Information

WISE-7517M-10 CR	WISE I/O Module with 10/20 Channels AI and 2-port Ethernet Switch. (RoHS)	Art. No. 155729
-------------------------	---	-----------------

Accessories

GPSU06U-6	24V/0.25A, 6 W Power Supply
MDR-20-24	24V/1A, 24 W Power Supply with DIN-Rail Mounting
NS-205 CR	Unmanaged 5-Port Industrial Ethernet Switch (RoHS)
NS-205PSE CR	Unmanaged 5-Port Industrial PoE Ethernet Switch (RoHS)